

# **SAILING Champions League 2015 18<sup>th</sup> to 20<sup>th</sup> of September 2015**



## **SAILING INSTRUCTION.**

### **1 Organizer**

The Organising Authority (OA) is Yacht Club Costa Smeralda in conjunction with the Konzeptwerft Holding GmbH.

### **2 Rules**

2.1 The Event will be governed by

- (a) The 'rules' as defined in the RRS.
- (b) The rules for Handling Boats (SI Addendum C) that also applies to any practice sailing and sponsor races. Class rules will not apply.
- (c) Any prescriptions of the national authority that will apply will be posted on the official notice board.
- (d) All races will be sail under ISAF ADD "Q"

2.2 Changes of Rules.

- (a) RRS 26 is change, se SI 12
- (b) RRS 27.1 is amended, with the following:  
"no later than the warning" is change to "no later than the 1 min. signal"

### **3 Advertising**

The rules on advertising are mention in SI Addendum D

### **4 Notices to competitors**

Notices to competitors will be posted on the official notice board located outside the Race Office.

### **5 Changes to the sailing instructions**

Changes to the sailing instructions will be posted on the official notice board or distributed to all teams not less/later than 30 minutes before they will take effect, except that any change to the time schedule of races will be posted by 20.00 the day before it will take effect

### **6 Signals made ashore**

- 6.1 Signals made ashore will be displayed from the signal mast in front of the Race Office
- 6.2 When flag AP is displayed ashore, '1 minute!' is replaced with 'not less than 30 minutes' in the race signal AP.

## 7 **Schedule**

**Thursday:** Registration from 09:00am to 06:00pm  
Practice from 12:00pm to 06:00pm

**Friday:** Registration from 08:00am to 12:30pm  
Practice from 09:30am to 12:30pm  
Skippers briefing is at 01:00pm  
First warning signal is at 02:30pm  
Opening ceremony is at 08:00pm

**Saturday:** Skippers briefing at 08:00am  
First warning signal at 09:30am  
After Sailing: social

**Sunday:** Skippers briefing at 08:00am  
First warning signal at 09:30am  
Last possible warning signal at 03:00pm  
Price giving ceremony at 04:00pm

- 7.1 Training Opportunity: All participants have access to training in the boats for periods of 45 minutes, according to a plan published on Thursday morning at 09:00.
- 7.2 There will be Briefing (attendance is compulsory for a crewmember for each team) Friday. 01.00pm
- 7.3 Subsequent races will be started immediately after crew changes have finished after the finishing of the previous race. The crew change will be on the water as schedule in Appendix B.

## 8 **Class flag**

Class flag is a "White flag with boating league's logo." There will maybe come another class flag

## 9 **Race Area**

**Will be describe later see appendix F**

## 10 **Course**

Appendix A shows the course and the order in which marks are to be rounded or passed and their required side.

## **11 Marks**

11.1 Mark 1 is either a yellow, or a red, or a green inflatable cylindrical mark.

- (a) This will be indicated at the 1-minute signal by displaying a flag with the color of the mark.

11.2 Marks 2a and 2b, are yellow inflatable cylindrical marks.

11.3 Start and finishing's mark is a flag buoy with an orange flag on one end and an orange flag on the committee boat in the other end.

11.4 Replacement mark is either a green or a red inflatable cylinder.

## **12 Start**

12.1 The starting line is between the orange flags on the starting line marks.

12.2 RRS 26 is amended as follows:

- (a) Warning signal: 3 minutes before the start. The class flag will be displayed, with one sound signal.
- (b) Preparation signal: 2 minutes before the start signal flag "P" will be displayed, with one sound signal
- (c) One-minute signal: 1 minute before the starting signal, signal flag "P", will be lowered, with one sound signal
- (d) Start signal: Class flag is lowered with one sound signal

## **13 Change of course.**

13.1 The Race committee may change mark 1 in the following way.

- (a) When rounding the gate:
  - (1) Displaying red, or green or yellow flag with repeated sound signals.
    - (a) This means: Mark M1 is replaced by the mark with the colour of the signal.

## **14 Shortening the course**

The course will not be shortened.

## **15 The finishing line.**

The finishing line is identical with the start line.

## **16 Protest and request for redress**

16.1 ISAF ADD "Q" will be used for direct judging.

16.2 Breaches of the following sailing instruction will not be grounds for protest by a boat. Penalty for those infringements will be initiated by an umpire according to ADD "Q"

- (a) 19.1 personal buoyancy

- (b) 19.3 prohibited area
  - (c) C4.1 crew position
  - (d) C4.2 bowsprit.
- 16.3 There will be an International jury for the event. Their decisions cannot be appealed according to RRS 70.5

## **17 Target time**

- 17.1 Target time for each race is 12-15 minute.
- 17.2 Time limit for first boat finishing is 25 minute.
- 17.3 Boat that does not finish within 5 min after the first boat has finished, will be scored DNF. This change RRS 35, A4 and A5

## **18 Scoring**

- 18.1 Low point system will be used under RSS
- (a) DNF, DNS, DSQ, RAF etc.. gives 9 point.
- 18.2 Three Flights are required by all competitors in order to constitute a championship.
- 18.3 Each boats score will be the sum of her scores for all races. This change RRS A2
- 18.4 If at the end of the regatta, some of the competitors have sailed and uneven number of races, due to incomplete flights, the competitors missing a race will be scored according to RRS A10(a)
- 18.5 If a participant is unable to start a race because the organizer cannot supply a boat for them, the participant will have an average score for this race, according to RRS A10(b). (the average will be calculated based on the races that were sailed before the race mentioned)

## **19 Security / Restricted area**

- 19.1 Each participant must wear a personal flotation device when racing. Excluded are briefly while changing or adjusting personal clothing. Wet suits and dry suits are not considered as a personal flotation device.
- 19.2 A boat that retires from the race shall immediately notify the race committee.
- 19.3 There might be a restricted area. This area is prohibited to sail in and rank as an obstruction. The marks that limit the area may be touch. (see description on the notice board)

## **20 Replacement of crew and equipment**

- 20.1 When a skipper or crew is unable to continue in the event, the IJ may authorize a change.
- 20.2 Substitution of damaged or lost equipment and repairs may only be done by the organizers repairmen, or under their management.

## **21 Official boats.**

The official boats will be marked with white flags with the following text:

Repair boat: " service "  
Umpire boat: " Umpire "  
Press boat: "Press "  
Transport Boats: " t1-t2-t3-t4-t5-t6-t7-t8"

## **22 Electronic**

- 22.1 While racing, a participant may not use any electronic devices except a watch for timing the start. If this watch has functions other than the clock, they must not be used.
- 22.2 General information from the race committee will be given on a public VHF channel. The channel will be posted on the official notice board. The radio will be on the tiller.

## **23 Coaches and support boats**

- 23.1 Coaches and support boats shall be marked with the club name or identify the club they are supporting.
- 23.2 Coaches and support boats must keep a minimum distance of 50 meters to any racing boat and will sail in a way so they do not make waves or swells in the racing area.

## **24 Damage**

- 24.1 If there is a damage on a boat, the participant shall complete a damage report as described in Appendix E.
- 24.2 Each skipper is responsible for the damage or loss to their boat unless responsibility is otherwise assigned by the umpires or the IJ.

.

Appendix:

Appendix A: The course

Appendix B: The format and pairings list.

Appendix C: Handling the boats

Appendix D: Advertising

Appendix E: Damage.

Appendix F: Course area

Appendix Q: Direct judging

**Appendix A:**

Mark rounding order

No pennant: Start – M1 – M2a/M2b – M1 – Finish

Pennant 1: Start – M1 – M2a/M2b – M1 – M2a/M2b – Finish

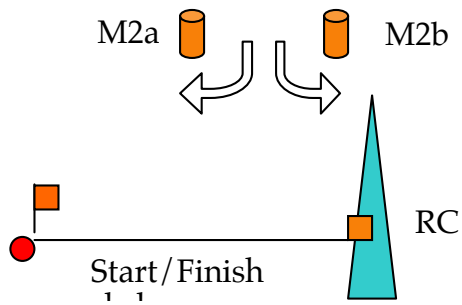
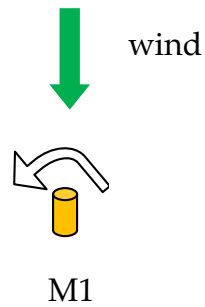

## **Appendix C: Handling the boats.**

### **C 1 General**

The organizers aims to get the boats equal. Any differences in the boats cannot be ground for redress.

### **C 2 Prohibited Actions**

To prevent damage to the boat and crew the following is prohibited, except in an emergency or under the instructions of the race committee:

C2.1 To sail the boat in a way that can lead to damage to the boat or crew.

C2.2 Any substitution, change or assembly of spare parts and equipment, if they have not been supplied by the organizer.

C2.3 Using the equipment for purposes other than its intended use.

C 2-4 Moving the equipment from its normal position, except to fix it properly.

C 2-5 Write on the hull, cockpit or sail, perforation of the sails or installation of additional ticklers on the sails.

### **C3 Receipt and delivery of boats**

C3.1 When a crew receives a boat, it has 3 minutes to control that the boat is ok and report possible errors for the race committee (hail to either start boat, repair boat or the umpire boat).

After this, the race committee may start the procedure for the next race.

Information to the organizer after the warning signal has been displayed will not be reason for postponement for repair.

C3.2 The crew sailing the boat shall report any damage or problem with the boat, before turning over a boat to the next crew. This can be done to the repair boat or the boat changing the crew.

### **C4 Other rules that apply while boats are racing**

#### **C4.1 CREW POSITIONING**

Except for momentary sail handling and/or repair needs, crew shall remain behind the mast while on deck.

Crew shall not stand and lean out over the cockpit safety lines or stern rails to promote roll tacking, roll gybing or to increase hiking leverage.

While seated on deck, crew shall have the base of their spine on the deck and inboard of the cockpit safety lines at all times.

Not more than three crew members may have their legs outboard of the sheerline.

When tacking or gybing, crew shall not hang, push or pull on the shrouds, mast, cockpit safety lines, stanchions or any other item to promote the maneuver.

#### C4.2 Bowsprit

The bowsprit shall be fully retracted at all times except when the gennaker is being set, is set, or is being retrieved, and shall be retracted at the first reasonable opportunity after the retrieval.

An extended bowsprit shall not be considered part of the boat for the purposes of:  
Establishing an overlap, or establishing right of way, unless the gennaker is set.

#### C4.3 Standing rigging and lifelines

The setting of the shrouds, forestay and lifelines (security lines out of the cockpit) may only be change in accordance with instructions from the race committee or a repairman. The backstay may be adjusted while sailing.



**Appendix D:**

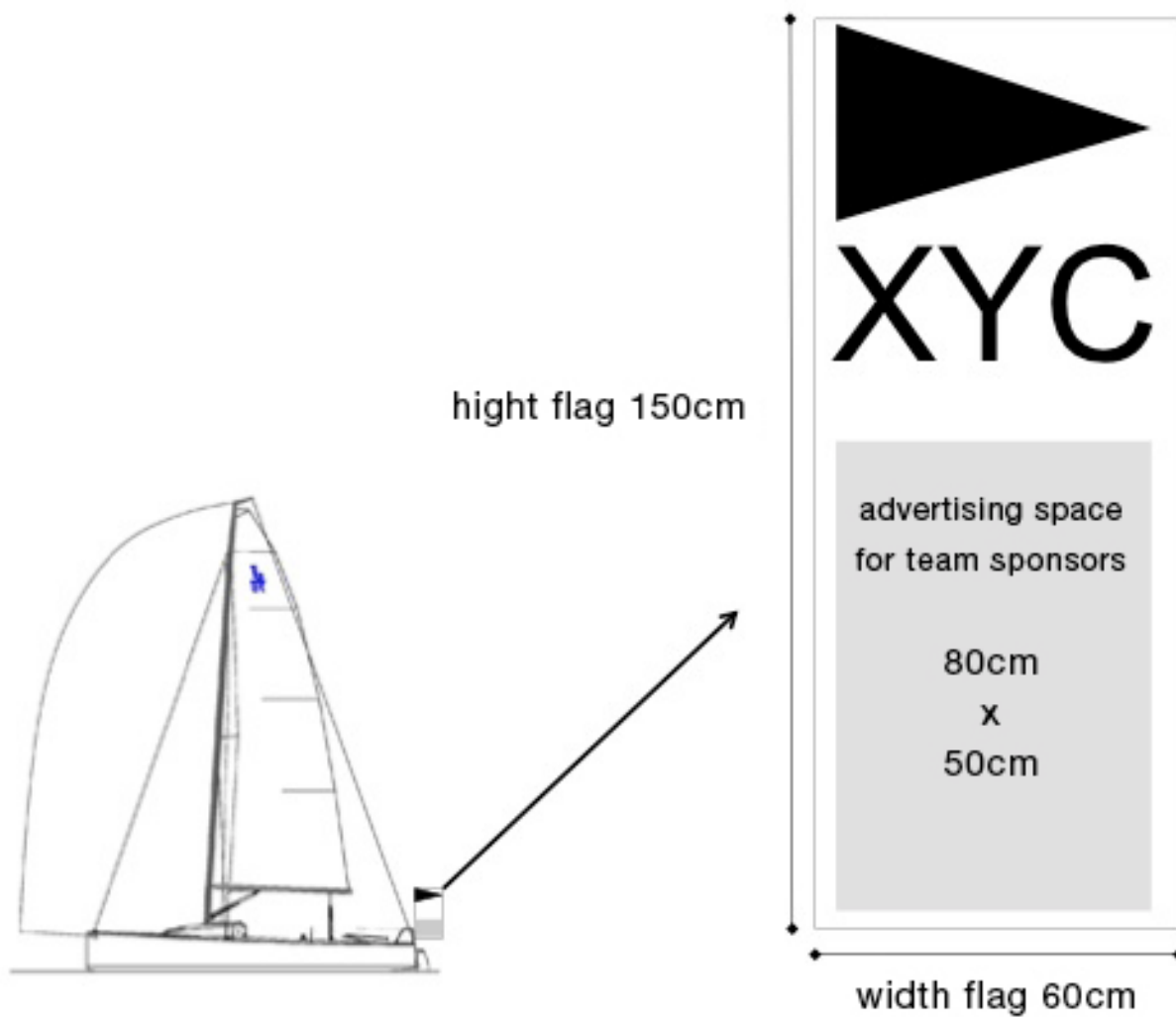

**Appendix E:**

## **Appendix F:**

## **ADDENDUM Q - UMPIRED FLEET RACING**

These sailing instructions change the definition Proper Course, and rules 20, 28.2, 44, 60, 61, 62, 63, 64.1, 65, 66, 70, 78.3 and B5.

### **Q1 CHANGES TO RACING RULES**

Additional changes to rules are made in instructions Q2, Q3, Q4, and Q5.

#### **Q1.1 Changes to the Definitions and the Rules of Part 2 and Part 4**

- (a) Add to the definition Proper Course: 'A boat taking a penalty or maneuvering to take a penalty is not sailing a proper course.'
- (b) When rule 20 applies, the following arm signals are required in addition to the hails:
  - (1) for 'Room to tack', repeatedly and clearly pointing to windward; and
  - (2) for 'You tack', repeatedly and clearly pointing at the other boat and waving the arm to windward.

Instruction Q1.1(b) does not apply to boards.

#### **Q1.2 Changes to Rules Involving Protests, Requests for Redress, Penalties and Exoneration**

- (a) The first sentence of rule 44.1 is replaced with: 'A boat may take a One-Turn Penalty when she may have broken a rule of Part 2 (except rule 14 when she has caused damage or injury) or rule 31 or 42 while racing.'
- (b) For boards, the One-Turn Penalty is one 360 degree turn with no requirement for a tack or a gybe.
- (c) Rule 60.1 is replaced with 'A boat may protest another boat or request redress provided she complies with instructions Q2.1 and Q2.4.'
- (d) The third sentence of rule 61.1(a) and all of rule 61.1(a)(2) are deleted. Rule B5 is deleted.
- (e) Rules 62.1(a), (b) and (d) are deleted. In a race where this addendum applies, there shall be no scoring adjustments for redress given under any of these rules for a previous race.
- (f) Rule 64.1(a) is changed so that the provision for exonerating a boat may be applied by the umpires without a hearing, and it takes precedence over any conflicting instruction of this addendum.
- (g) Rules P1 to P4 shall not apply.

### **Q2 PROTESTS AND REQUESTS FOR REDRESS BY BOATS**

#### **Q2.1**

While racing, a boat may protest another boat under a rule of Part 2 (except rule 14) or under rule 31 or 42; however, a boat may only protest under a rule of Part 2 for an incident in which she was involved. To do so she shall hail 'Protest' and conspicuously display a red flag at the first reasonable opportunity for each. She shall remove the flag before, or at the

first reasonable opportunity after a boat involved in the incident has taken a penalty voluntarily or after an umpire's decision. However, a board need not display a red flag.

#### Q2.2

A boat that protests as provided in instruction Q2.1 is not entitled to a hearing. Instead, a boat involved in the incident may acknowledge breaking a rule by taking a One-Turn Penalty as described in rule 44.2. If the protested boat does not take a penalty voluntarily, an umpire will decide whether to penalize any boat and signal the decision as provided in instruction Q3.1.

#### Q2.3

At the finishing line, the race committee will inform the competitors about each boat's finishing place or scoring abbreviation. After this has been done for all boats, the race committee will promptly display flag B with one sound. Two minutes later flag B will be removed with one sound.

#### Q2.4

A boat intending to

- (a) protest another boat under a rule other than instruction Q3.2 or Q4.2(a), or a rule listed in instruction Q2.1,
- (b) protest another boat under rule 14 if there was contact that caused damage or injury, or
- (c) request redress

shall hail the race committee before or during the display of flag B. The same time limit applies to protests under instructions Q5.4 and Q5.5. The protest committee may extend the time limit if there is good reason to do so.

#### Q2.5

The race committee will promptly inform the protest committee about any protests or requests for redress made under instruction Q2.4.

### **Q3 UMPIRE SIGNALS AND IMPOSED PENALTIES**

#### Q3.1

An umpire will signal a decision as follows:

- (a) A green and white flag with one long sound means 'No penalty.'
- (b) A red flag with one long sound means 'A penalty is imposed or remains outstanding.' The umpire will hail or signal to identify each such boat.
- (c) A black flag with one long sound means 'A boat is disqualified.' The umpire will hail or signal to identify the boat disqualified.

#### Q3.2

- (a) A boat penalized under instruction Q3.1(b) shall take a One-Turn Penalty as described in rule 44.2.

- (b) A boat disqualified under instruction Q3.1(c) shall promptly leave the course area.

#### **Q4 PENALTIES AND PROTESTS INITIATED BY AN UMPIRE; ROUNDING OR PASSING MARKS**

##### Q4.1

When a boat

- (a) breaks rule 31 and does not take a penalty,
- (b) breaks rule 42,
- (c) gains an advantage despite taking a penalty,
- (d) deliberately breaks a rule,
- (e) commits a breach of sportsmanship, or
- (f) fails to comply with instruction Q3.2 or to take a penalty when required to do so by an umpire,

an umpire may penalize her without a protest by another boat. The umpire may impose one or more One-Turn Penalties to be taken as described in rule 44.2, each signalled in accordance with instruction Q3.1(b), or disqualify her under instruction Q3.1(c), or report the incident to the protest committee for further action. If a boat is penalized under instruction Q4.1(f) for not taking a penalty or taking a penalty incorrectly, the original penalty is cancelled.

##### Q4.2

- (a) A boat shall not round or pass a mark on the wrong side. If she does so, she may correct her error as provided in rule 28.2 only if she does so before she rounds or passes the next mark or finishes.
- (b) When a boat breaks instruction Q4.2(a) and fails to correct her error before rounding or passing the next mark or finishing, an umpire may disqualify her under instruction Q3.1(c).

##### Q4.3

An umpire who decides, based on his own observation or a report received from any source, that a boat may have broken a rule, other than instruction Q3.2 or Q4.2(a) or a rule listed in instruction Q2.1, may inform the protest committee for its action under rule 60.3. However, he will not inform the protest committee of an alleged breach of rule 14 unless there is damage or injury.

#### **Q5 PROTESTS; REQUESTS FOR REDRESS OR REOPENING; APPEALS; OTHER PROCEEDINGS**

##### Q5.1

An umpire may take no proceedings of any kind in relation to any action or non-action.

##### Q5.2

A boat may not base an appeal on an alleged improper action, omission or decision of the umpires or the protest committee. In rule 66 the third sentence is changed to 'A party to the hearing may not ask for a reopening.'

#### Q5.3

- (a) Protests and requests for redress need not be in writing.
- (b) The protest committee may take evidence and conduct the hearing in any way it considers appropriate and may communicate its decision orally.
- (c) If the protest committee decides that a breach of a rule has had no effect on the outcome of the race, it may impose a penalty of points or fraction of points or make another arrangement it decides is equitable, which may be to impose no penalty.

#### Q5.4

The race committee will not protest a boat, except following a report under rule 43.1(c) or 78.3.

#### Q5.5

The protest committee may protest a boat under rule 60.3. However, it will not protest a boat for breaking instruction Q3.2 or Q4.2(a), a rule listed in instruction Q2.1, or rule 14 unless there is damage or injury.